

## Technical specifications sheet

Part number **290023351100U**

Description **DPVCF 2/10 B~Flanged NW25~0,75kW 230/400V~50Hz 2P~IEC 80A~IE3~Fixed Ca SiC EPDM**

Vertical centrifugal pump, suction and discharge connections in-line.

### Quotation details

Quotation number

Project

Position

### Search criteria

Medium to be pumped  
 Flow 1,90 m<sup>3</sup>/h  
 Pressure 62,5 mwc

### Hydraulic efficiency

Minimum efficiency index according: MEI ≥ 0.70  
 Commission Regulation (EU) No 547/2012

### Actual duty point

Flow 1,9 m<sup>3</sup>/h  
 Pressure 62,5 mwc  
 NPSH 1,6 m  
 Efficiency 53,6 %  
 Motor power 0,6 kW  
 Frequency 50,0Hz

### Connection base

Connection type Flanged  
 DIN connection standard EN 1092-2  
 ASME connection standard  
 JIS connection standard  
 DIN connection size NW25  
 ASME connection size  
 JIS connection size  
 DIN connection pressure class PN25/40  
 ASME connection pressure class  
 JIS connection pressure class  
 Material S/D casing Cast Iron JS1030  
 Material flanges Cast Iron JS1030  
 Material baseplate Cast Iron JS1030

### Seal data

Shaft diameter ø 12mm  
 Seal diameter ø 12mm  
 Construction shaft seal Fixed  
 Seal code 11  
 Shaft seal type MG12-G60  
 Material mechanical seal B Q1 E GG  
 Material shaft seal rotor Ca  
 Material shaft seal stator SiC  
 Material shaft seal elastomer EPDM  
 Material pump elastomer EPDM  
 Material seal cover  
 Pressure class shaft seal PN10  
 Temperature range shaft seal -20/+100°C

### Basic hydraulic data

Maximum working pressure PN40+120°C  
 Maximum liquid temperature 140°C+PN16  
 Minimum liquid temperature -20°C  
 Material hydraulic AISI304

### Plug

Air relieve construction Vent. plug  
 Material plug AISI304

### For details contact

DP Pumps  
 PO Box 28  
 2400AA Alphen a/d Rijn  
 The Netherlands

NL



# Hydraulic performance sheet

Part number **290023351100U**

Description **DPVCF 2/10 B-Flanged NW25~0,75kW 230/400V~50Hz 2P~IEC 80A~IE3~Fixed Ca SiC EPDM**

Vertical centrifugal pump, suction and discharge connections in-line.

**Search criteria**

Medium to be pumped

Flow 1,90 m3/h  
 Pressure 62,5 mwc

**Actual duty point**

Flow 1,90 m3/h  
 Pressure 62,5 mwc  
 Efficiency 53,6 %  
 NPSH 1,6 m  
 Power 0,60 kW  
 Frequency 50,0Hz

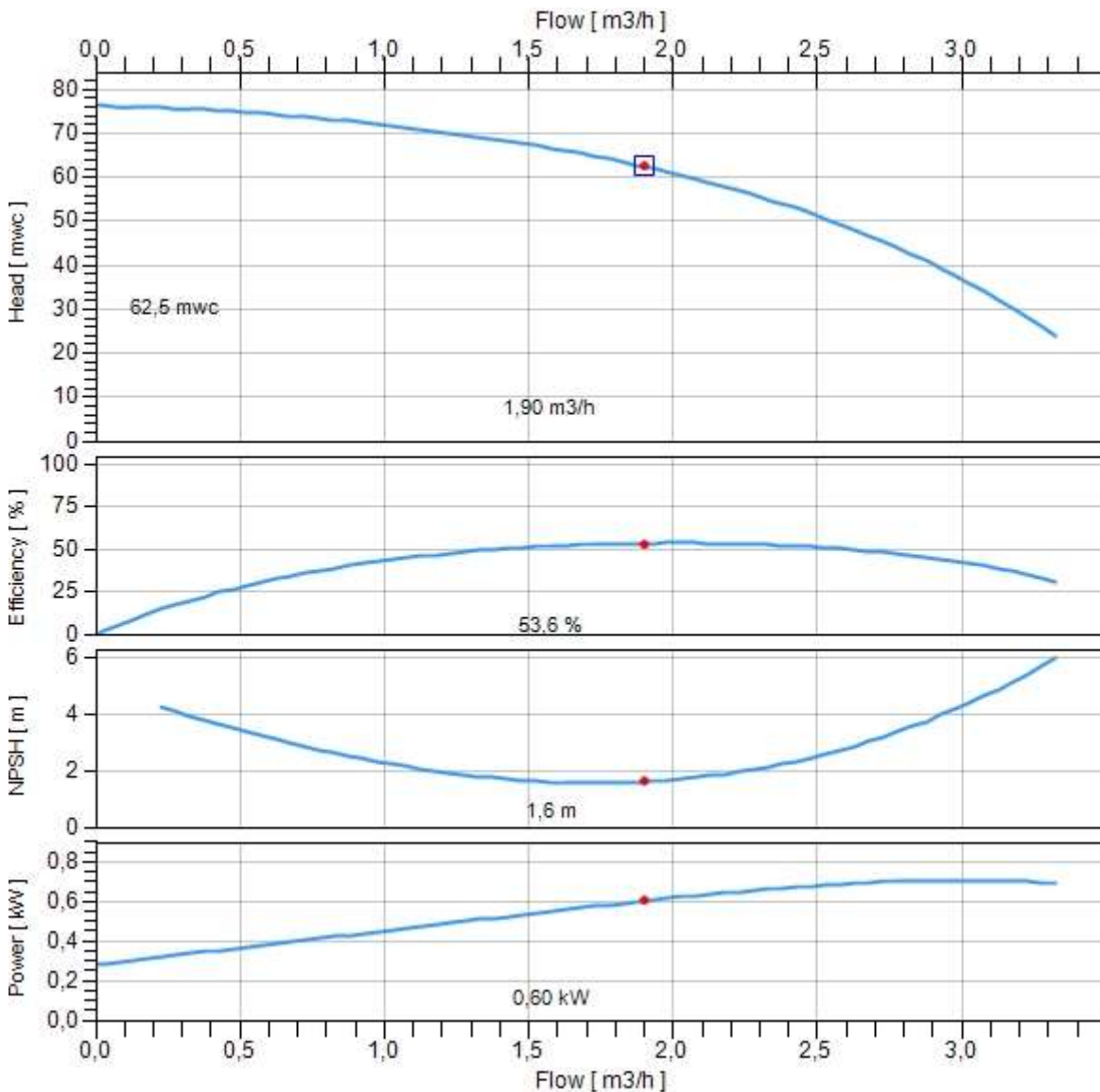

Duty point

- Actual
- Required

Dimensions sheet

Part number **290023351100U**

Description **DPVCF 2/10 B~Flanged NW25~0,75kW 230/400V~50Hz 2P~IEC 80A~IE3~Fixed Ca SiC EPDM**

Vertical centrifugal pump, suction and discharge connections in-line.

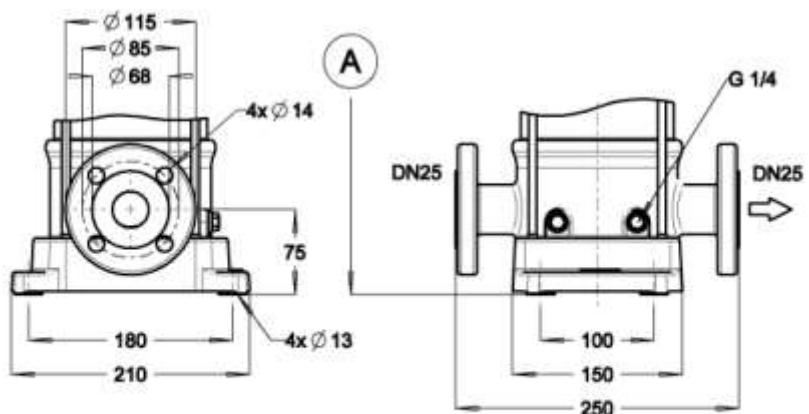
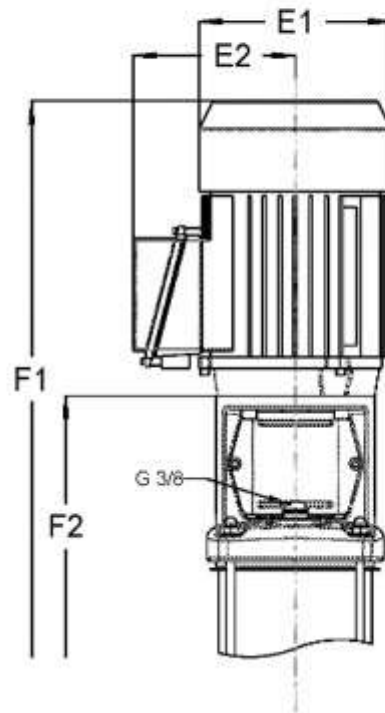

Motor width (E1)	150mm
Motor width (E2)	115mm
Total height (F1)	700mm
Total height (F2)	466mm
Total net weight	32kg

## Motor specifications

Part number **3710051007**

Description **Motor DMC 0,75kW 230/400V 2P IE3 80A IP55 Pos. 800**

### Electric Data

Rated power output	0,75kW
Maximum power output	1,1kW
Rated voltage	230/400V
Phases	3ph
Frequency	50/60Hz
Voltage range	207-253/360-440V
Motor poles	2P
ATEX class	
Duty class	S1
Insulation class	F (rise-B)
Moment of inertia	0,0011kgm <sup>2</sup>
Motor standard	IEC
Capacitor	
Motor efficiency	80,7%/80,7%
Motor efficiency class	IE3

### 50Hz

Tolerance rated voltage	±10%
Rated speed	2880rpm
Starting current factor (Ia/In)	6.6
Rated current (In)	3,1/1,8A
Maximum current (Imax)	4,2/2,4A
Rated Cos phi	0.76
Sound pressure	55dB(A)(A)
Rated nominal torque	2,5Nm
Rated starting torque	9,2Nm

### 60Hz

Tolerance rated voltage	-10% / +25%
Rated speed	3460rpm
Starting current factor (Ia/In)	6.2
Rated current (In)	2,8/1,6A
Maximum current (Imax)	4,0/2,3A
Rated Cos phi	0.84
Sound pressure	58dB(A)(A)
Rated nominal torque	2,1Nm
Rated starting torque	6,8Nm

### Motor protection

Motor protection class	IP55
Temperature sensor	
Rain cover	
Anti condensation heater	

### Mechanical data

Shaft execution	smooth shaft
Maximum starts per hour	180
Cable gland	1xM20x1,5
VFD allowance	VFD allowed max. 400V

### Dimensions

Diameter shaft A1	19mm
Length shaft A2	40mm
Diameter motor E1	150mm
Terminal box height E2	115mm
Diameter flange P	120mm
L. motor (without shaft) LB	234mm
Frame size	80A
Motor construction type	IM V18
Motor face	IEC 60034-7 Form FT 100

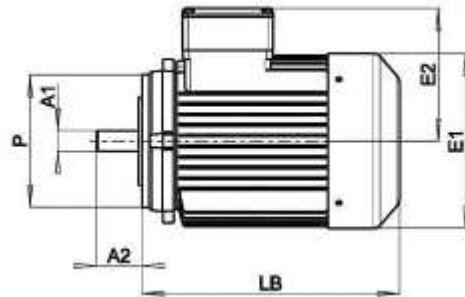

### Bearings / lubrication

Grease nipple	
Bearing fixation pos	D-end
D-end bearing type	6204-2RS-C3
Bearing grease	Lithium based -20°/+160

### Details

Motor label	DMC
Weight	9,7 kg
Lifting lugs	
Motor finish	RAL5002
Rated max. amb. temp.	40°C
Material housing	Aluminium